

**Profile**

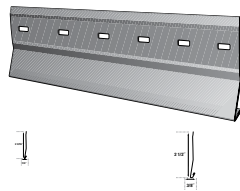

Standard      Wide  
**Aluminum Starter Strip**

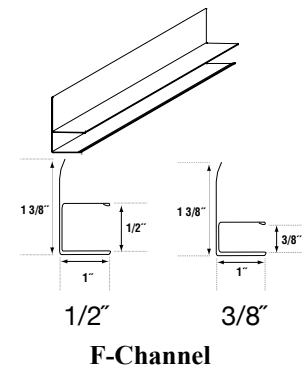
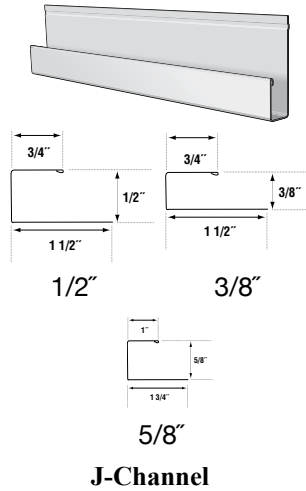
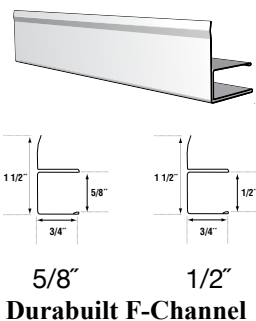

**Physical Characteristics and Manufacturing Data**

- Coating:** Two-coat waterbase acrylic
- Gloss:** 10-14 @ 60°, ASTM D 523-80
- Flexibility:** No removal of finish with 600 Scotch Tape on a 2T bend. NCCA 11-19
- Pencil Hardness:** HB-H Eagle Turquoise, NCCA 11-12
- Adhesion:** Excellent, ASTM D 3359-83
- Impact:** No visual cracking or finish release when subjected to impact in inch pounds equal to one and one half times the metal thickness. NCCA 11-6
- Humidity Resistance:** No loss of gloss, cracking or peeling after 3,000 hours @ 100% relative humidity. ASTM D 2247-86A
- Salt Spray Resistance:** No under-cutting of film from edges in excess of 1/16" or face blistering after 1,000 hours at 5% neutral salt spray. ASTM B 117-85
- Exterior Exposure:**
  - a. Fade: Max. #5 after 10 years at 45° south Florida exposure after removal of external deposits. ASTM D 2244-85
  - b. Chalk: Max. #8 rating on all colors with the exception of white within 10 years at 45° south Florida. ASTM D 659-86
- Dry Film Thickness:** .90-1.00 mils
- Solvent Resistance:** 100+MEK rubs
  - Meets the performance requirements of AAMA 1402-86

**Colors**

**3/8" J-Channel & F-Channel** - Autumn Beige, Black, Brandy, Classic Cream, Delray Sand, Dover White, Evening Gray, Forest, Georgian Gray, Graphite Gray, Irish Thistle, Island Pearl, Musket Brown, Natural Almond, Royal Brown, Sandy Tan, Savannah Blue, Shell, Silver Mist, Spanish Olive, Stone Mtn. Clay, Terratone  
**1/2" J-Channel** - Dover White, Georgian Gray, Island Pearl, Musket Brown, Natural Almond, Royal Brown, Sandy Tan Spanish Olive, Stone Mtn. Clay, Terratone  
**1/2" F-Channel** - Dover White, Georgian Gray, Irish Thistle, Island Pearl, Musket Brown, Natural Almond, Royal Brown, Sandy Tan Spanish Olive, Stone Mtn. Clay, Terratone  
**Durabuilt F Channels** - Dover White, Musket Brown  
**Window Head Flashing** -Dover White

**Product Information**

- J-Channel**  
 3/8" - For use with Triple 4 Soffit and Quad 4 Soffit  
 1/2" - For use with Double 6 Soffit  
 25 pieces, 12'0" long, 300 feet  
 Approximately 17 lbs./carton  
 5/8" Approximately 22 lbs./carton
- F-Channel**  
 3/8" - For use with Triple 4 Soffit and Quad 4 Soffit  
 1/2" - For use with Double 6 Soffit  
 25 pieces, 12'0" long, 300 feet  
 Approximately 37 lbs./carton
- Window Head Flashing (not shown)**  
 Acrylic smooth finish  
 20 pieces, 12'6" long  
 Approximately 18 lbs. / carton

**Aluminum Starter Strip (Standard)**  
 50 pieces, 10'0" long, 500 feet  
 Approximately 27 lbs./carton

**Aluminum Starter Strip (Wide)**  
 50 pieces, 10'0" long, 500 feet  
 Approximately 33 lbs./carton

**Galvanized Steel Starter Strip (Standard)**  
 25 pieces, 10'0" long, 250 feet  
 Approximately 30 lbs./carton

**Steel Starter Strip (Wide)**  
 25 pieces, 10'0" long, 250 feet  
 Approximately 36 lbs./carton

**Materials**

- Ultimate Tensile Strength:** 28 KSI (Average)
- Yield Tensile Strength:** 28 KSI (Average)
- Elongation:** 2% minimum
- Thickness:** 0.019" nominal (Commercial)  
 0.015" nominal (Durabuilt)